

Sharp machine tools

SHARP MODEL 350SDV 10.5" DOUBLE - SWIVEL HEAD BANDSAW



- 45°- 0°- 60° swivel with quick release
- Gear-driven 3Hp DC Variable speed motor
- Simply dial your desired blade speed
- Heavy 1" blade with carbide pad blade guides
- Quick lever tightened vise
- Perfectly balanced saw head for constant feed rates

SHARP MODEL 350SDV 10.5" DOUBLE - SWIVEL HEAD BANDSAW

FEATURES



CHIP CLEARING BRUSH



WISE STABILIZER

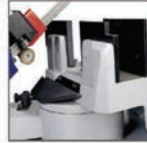

90 DEGREE POSITIONER



HEAVY-DUTY HINGE

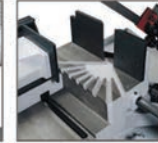

DUAL-ANGLE VISE

AVAILABLE OPTIONS



79" INFEEED TABLE





120" OUTFEED TABLE WITH
PRECISION FENCE AND MATERIAL STOP



BUNDLING ATTACHMENT



CUTTING CAPACITY

| ° | inch |  |  |  |
|-------|------|-------------------------------------------------------------------------------------|-------------------------------------------------------------------------------------|-------------------------------------------------------------------------------------|
| 90° | | 10.6 | 10 | 13.75 x 8.6 |
| 45° | | 9.5 | 8.6 | 9.5 x 6.3 |
| 60° | | 6.3 | 6 | 6 x 6 |
| 45° L | | 8.26 | 7 | 7 x 7 |

604 9863221



- Gear driven – no belts to change (simply dial your desired blade speed)
- Heavy 1" blade with carbide pad blade guides (coolant is forced through both infeed and outfeed guides)
- Blade tension: hydraulic with auto shut-off sensor if blade breaks
- Quick- lever tightened vise
- 3 HP motor: run on 3 phase or single phase 220v

Dual cutting control

- Gravity self feeding*, hydraulically controlled with auto shut-off
- Manually activated and counterbalanced for rapid cutting of smaller or delicate work pieces

*feed rate is constant from start to finish and does not accelerate as saw head descends

3HP 208/220V 1PH/3PH

Weight 900lbs

Optional infeed and outfeed tables available

Sharp

MACHINE TOOLS

Proudly providing North American Representation for:

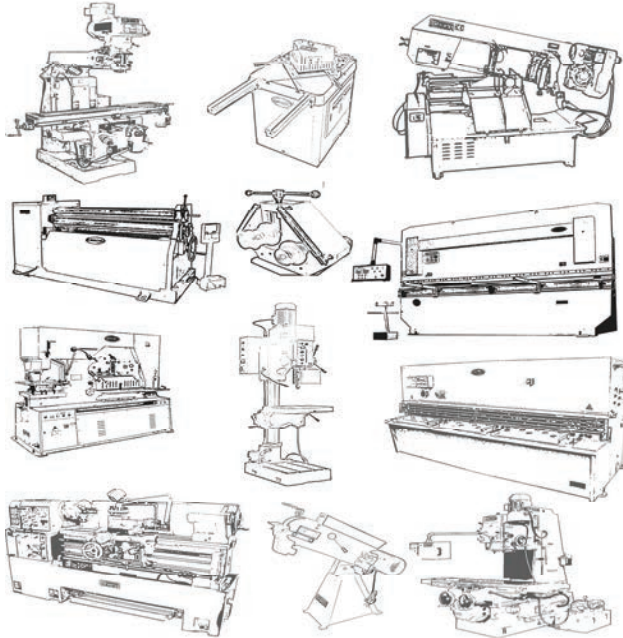

Head office for direct North American sales and Worldwide export:

Sharp Industries Ltd
1422 Pemberton Avenue
North Vancouver BC Canada V7P2S1
Telephone 604 986 3221 Fax 604 988 9562

Sharp machine tools

Toll-free 1 877 986 3221
Email
sales@sharpmachinetools.com