

The SHARP Lathe. North America's choice since 1974

**Sharp**

machine tools

## **SHARP SMT 1550**

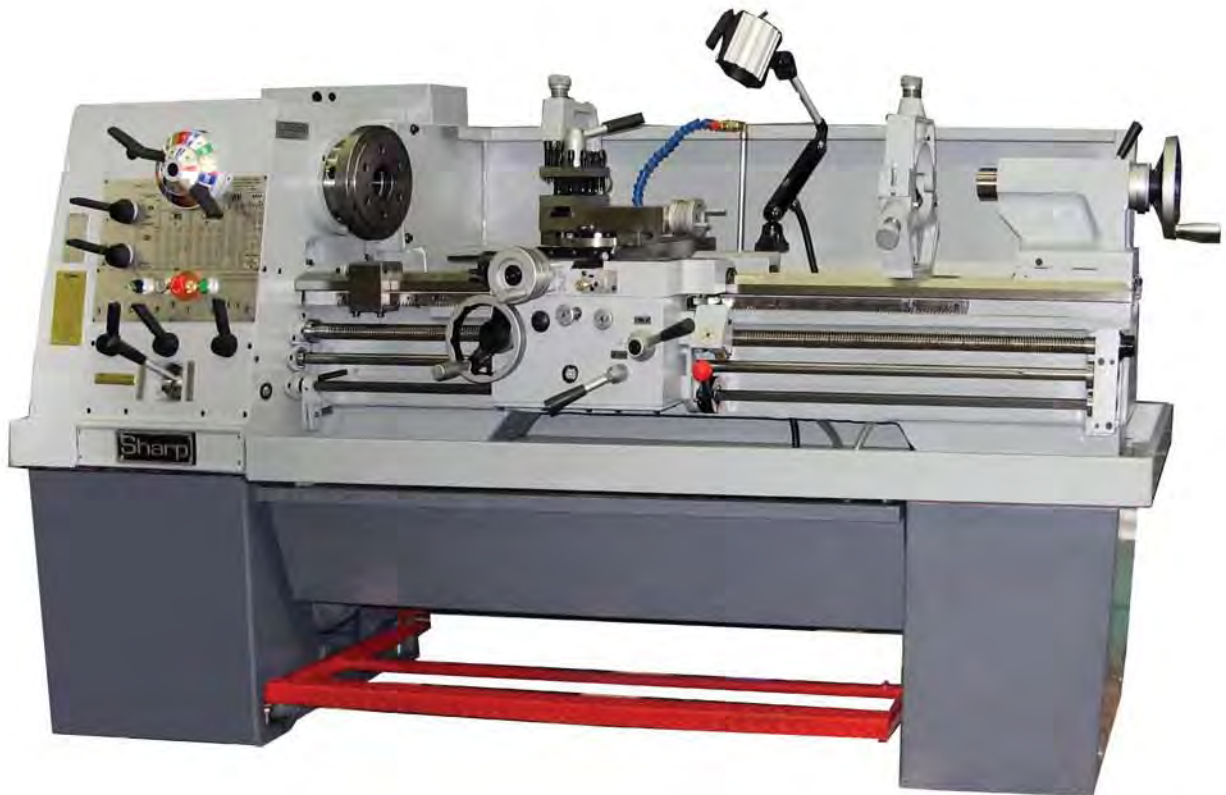

### Features

- A high quality production grade lathe with a time proven design
- Front pull out chip tray
- Hardened and ground bedways
- Pressure lubricated headstock for proper lubrication and cooling
- Cross slide and bedways are lubricated with a carriage-mounted pump
- Carriage travel has an adjustable overload trip clutch and micrometer automatic travel stop
- Feed direction can be reversed at the carriage
- Virtually every imaginable inch and metric thread is available without having to change gears. A full range of diametral and module pitches is also provided

**SMT 1550 15" swing 50" centers**

**2 1/8" spindle bore 7.5HP 11" wide bed**

Phone toll free 1-877-9863221

Email [sales@sharpmachinetools.com](mailto:sales@sharpmachinetools.com) Web <http://www.sharpmachinetools.com>

# Sharp

# machine tools

## SHARP SMT 1550 Specifications

Specifications	
Swing over bed	15" plus
Bed width	11"
Swing over cross slide	9 ½"
Swing over gap	24"
Distance between centres	50"
Spindle speeds* (16)	25-2000 rpm
Inch threads (45)	2 – 72 tpi
Metric threads (39)	0.2 – 14 mm
Spindle motor	7 ½" hp
Spindle bore	2 1/8"
Spindle nose	Camlock D1-6
Tailstock taper	MT4
Net weight	3500 lbs
Shipping weight	3700 lbs

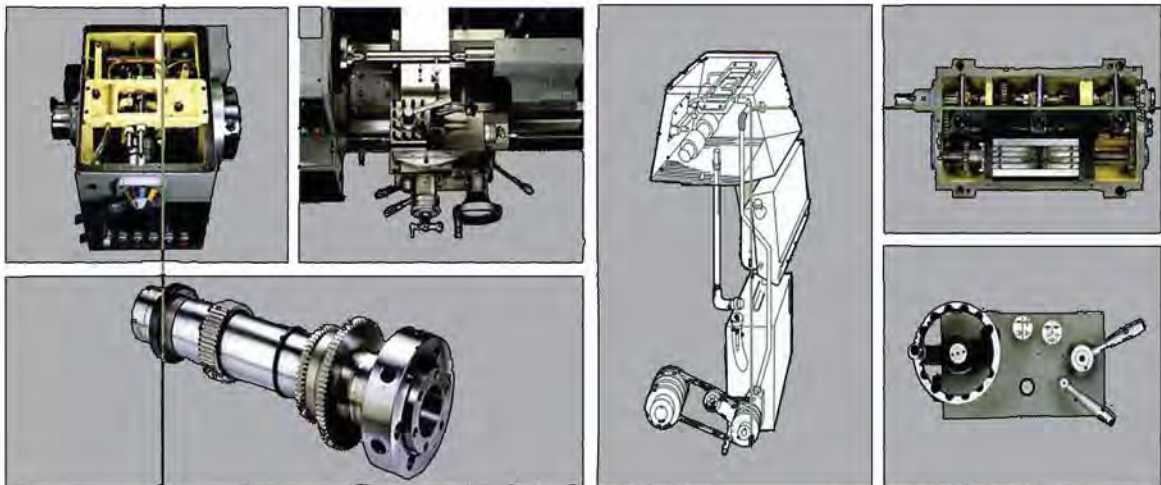

Available headstocks:

- conventional gear change
- conventional gear change with mechanical clutch
- inverter variable speeds (\*18-2500 rpm)  
(will allow operation on single phase power)

Sizes available 13", 15", 18", 20", 22", 26", 30" swing to 160" bed lengths

Phone toll free 1-877-9863221

Email [sales@sharpmachinetools.com](mailto:sales@sharpmachinetools.com) Web <http://www.sharpmachinetools.com>